

*Thank you for your purchase!*

## **LeatherSoft Upholstered Barstool with Black Metal Frame**

### **ASSEMBLY INSTRUCTIONS**

**Before You Begin:** Do not fully tighten screws until all pieces have been assembled.

Please identify all component parts and hardware pieces required before you begin. Carefully remove all of the components from the packaging and set aside for assembly. Assemble on a soft surface to prevent scratching during assembly.

**Caution:**

Tighten all components securely before use. Failure to do so may result in personal injury.

DO NOT use any sharp objects to open plastic wrapped components as damage to product or components may result.

**Warning:**







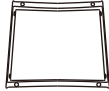

**CHOKING HAZARD** - Small Parts. Adult Assembly Required.

**DO NOT ALLOW CHILDREN TO CLIMB ON FURNITURE**

Serious or fatal injuries can occur from furniture tipping over. You must install Tipping Restraint Hardware (where included) to help prevent the unit from tipping and causing accidental injury, instability, death or damage. The tipping restraint is intended only as a safety measure, it is not a substitute for proper adult supervision.

To help prevent furniture from tipping over it must be permanently attached to the wall. Anti-Tip Safety Wall Straps suitable for the unit weight and wall materials (if not included) should be purchased and installed.

# PARTS

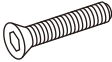
<b>A</b>		<b>METAL TUBE FRAME</b>	<b>E</b>		<b>CONNECTOR</b>	<b>I</b>		<b>Large Allen Wrench</b>	
<b>B</b>		<b>FOOTREST</b>	<b>F</b>		<b>M6*16 4pcs</b>	<b>SCREWS</b>	<b>J</b>		<b>Small Allen Wrench</b>
<b>C</b>		<b>SEAT BACK</b>	<b>G</b>		<b>M6*35 2pcs</b>	<b>SCREWS</b>			
<b>D</b>		<b>SEAT</b>	<b>H</b>		<b>M6*45 6pcs</b>	<b>SCREWS</b>			

## STEP 1

**STEP 1:** Turn Metal Tube Frames (Part A) upside down and attach footrest (Part B) to the Metal Tube Frames then tighten the pre-installed screws inside the Footrest using the Small Allen Wrench (Part J)

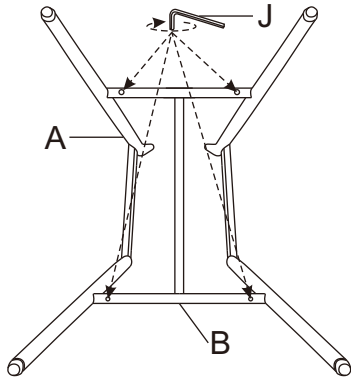

## STEP 2

**STEP 2:** Return chair to the upright position and attach the Connector (Part E) to the Metal Tube Frame (Part A) using M6\*16 Screws (Part F) and Large Allen Wrench (Part I)

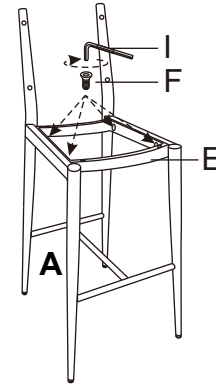

## STEP 3

**STEP 3:** Lay the Seat (Part D) upside down on a clean surface and align the holes of the Connector (Part E) with the pre-drilled holes on the underside of the seat. Attach the Connector using (4) M6\*45 Screws (Part H) and Large Allen Wrench (Part I)

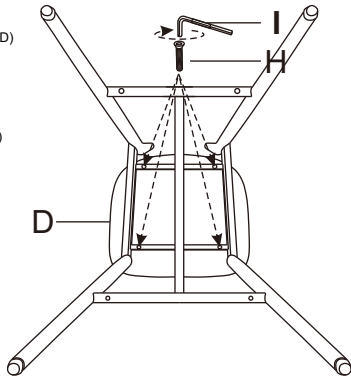

## STEP 4

**STEP 4:** Return chair to the upright position

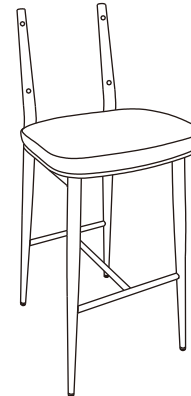

## STEP 5

**STEP 5A:** Attach Seat Back (Part C) to the lower part of the Metal Tube Frame (Part A) using M6\*45 Screws/Bolts (Part H) and Large Allen wrench (Part I)

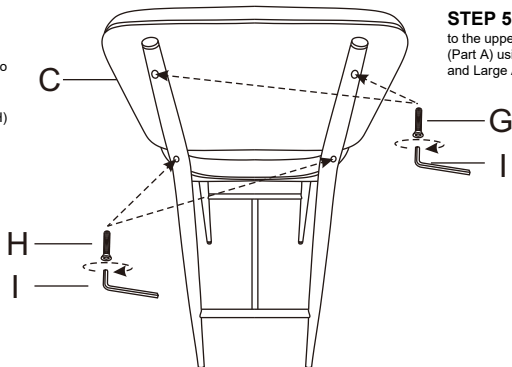

**STEP 5B:** Attach Seat Back (Part C) to the upper part of the Metal Tube Frame (Part A) using M6\*35 Screws (Part G) and Large Allen Wrench (Part I)

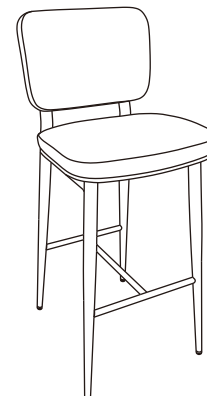

**STEP 6:** Return chair to the upright position and tighten all screws

