

Thank you for your purchase!

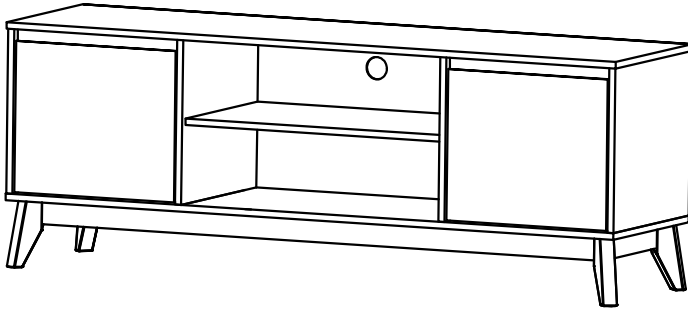

Wooden TV Stand with Adjustable Shelves

ASSEMBLY INSTRUCTIONS

Before You Begin:

Please identify all component parts and hardware pieces required before you begin. Carefully remove all of the components from the packaging and set aside for assembly. Assemble on a soft surface to prevent scratching during assembly.

Caution:

Tighten all components securely before use. Failure to do so may result in personal injury.

DO NOT use any sharp objects to open plastic wrapped components as damage to product or components may result.

Warning:

CHOKING HAZARD - Small Parts. Adult Assembly Required.

DO NOT ALLOW CHILDREN TO CLIMB ON FURNITURE

Serious or fatal injuries can occur from furniture tipping over. You must install Tipping Restraint Hardware (where included) to help prevent the unit from tipping and causing accidental injury, instability, death or damage. The tipping restraint is intended only as a safety measure, it is not a substitute for proper adult supervision.

To help prevent furniture from tipping over it must be permanently attached to the wall. Anti-Tip Safety Wall Straps suitable for the unit weight and wall materials (if not included) should be purchased and installed.

Our Warranty Statement

This warranty covers manufacturing defects associated with your new product. The product is warranted from the original purchase date and to the original purchaser for normal usage, according to the below-referenced specifications and limitations.













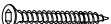

- Non-moving metal parts are warranted for 5 years.
- Component parts including pneumatic cylinder, control mechanism, base and casters are warranted for 2 years.
- All other items are warranted for 1 year.

Normal usage means use in compliance with the restrictions and weight limits specified for the product. In the absence of product-specific restrictions and weight limits, normal usage means use for no more than forty hours per week by persons weighing 250 lbs. or less. Coverage terminates if the product is sold or otherwise transferred. Repairs made by parties other than Belnick also void this warranty.

This warranty will not cover: (1) labor, freight, or damage from misuse, abuse, negligence, alteration, assembly, installation, attachments, accident, vandalism, acts of nature or any other event beyond the control of Belnick; (2) tearing, scratching, scuffing, or blemishing of leather or fabric; (3) cosmetic damage that may result from normal usage; (4) damage attributable to use by persons exceeding specified weight limits or commercial use exceeding forty hours per week; or (5) rust or other damage caused by exposure to moisture. The user assumes all risk of injury resulting from use of this product. Liability for incidental or consequential damage is excluded. Some states do not allow the exclusion or limitation of incidental or consequential damages, so the above limitation or exclusion may not apply to you.

PART AND HARDWARE

| PART LIST | | QTY |
|-----------|--------------------|-------|
| 1 | TOP PANEL | 1 PC |
| 2 | BOTTOM PANEL | 1 PC |
| 3 | LEFT SIDE PANEL | 1 PC |
| 4 | RIGHT SIDE PANEL | 1 PC |
| 5 | LEFT CENTER PANEL | 1 PC |
| 6 | RIGHT CENTER PANEL | 1 PC |
| 7 | CENTER SHELF PANEL | 1 PC |
| 8 | L/R TRIM PANEL | 2 PCS |
| 9 | BACK PANEL | 1 PC |
| 10 | BACK BRACE | 2 PCS |
| 11 | LEFT DOOR PANEL | 1 PC |
| 12 | RIGHT DOOR PANEL | 1 PC |
| 13 | LEG | 4 PCS |

| HARDWARE | | |
|----------|-------------------------------------------------------------------------------------------------------------------------------------------------------------------------------------------------------------------------------------------------------------------------------|--------|
| A | CAM LOCK A1  A2  A3  | 12 PCS |
| B | M8 X 30MM WOOD DOWEL  | 24 PCS |
| C | M6 X 50MM HEX WOOD SCREW  | 12 PCS |
| D | 5/8 PVC NAIL-IN FLOOR GLIDE  | 4 PCS |
| E | ALLEN WRENCH M4  | 1 PC |
| F | 2MM L BRACKET  | 4 PCS |
| G | M3.5 X 16MM SCREW  | 32 PCS |
| H | SOFT CLOSING 7/8 HINGES  | 4 PCS |
| I | METAL SHELF SUPPORT  | 4 PCS |
| J | HEX SCREW M6 x 70  | 8 PCS |
| K | LOCK WASHER M6  | 8 PCS |
| L | FLAT WASHER M6  | 8 PCS |

SELF-PREPARED TOOLS: Tools below are NOT included in package.



SCREWDRIVER



HAMMER

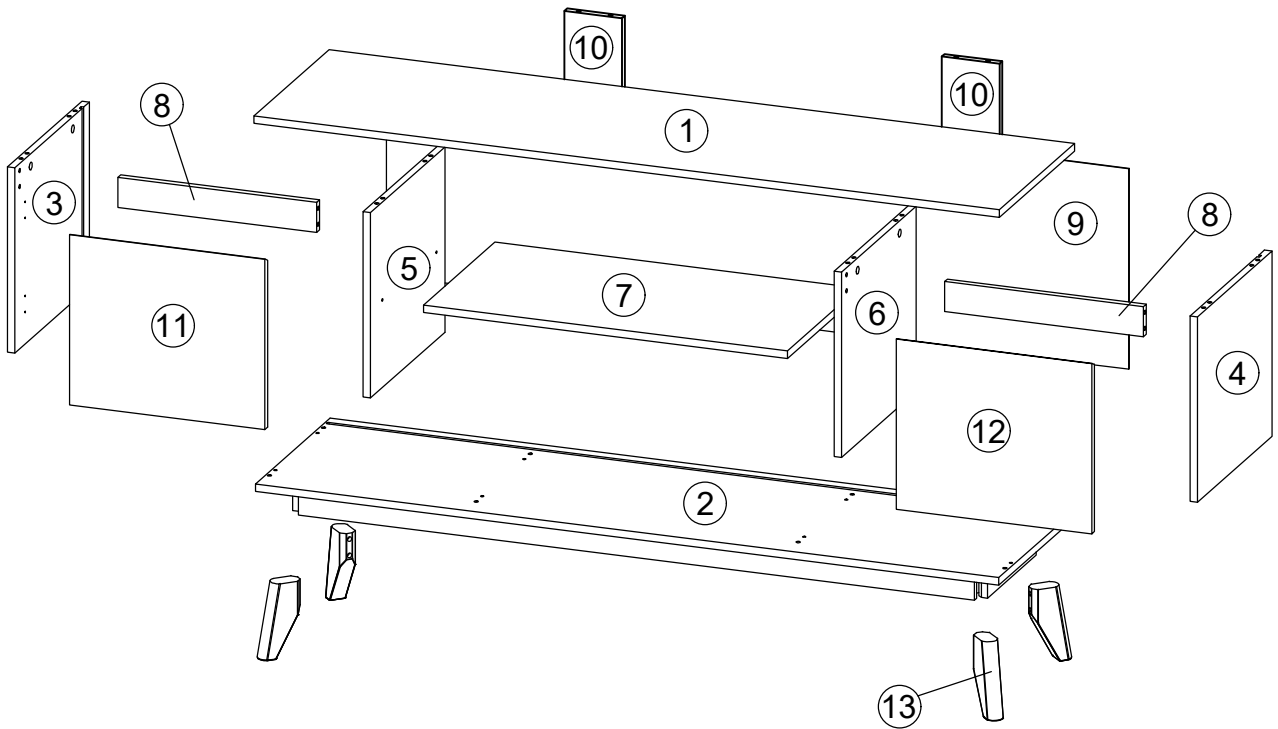

STEP 1



- Insert (12) Male Camlocks (Part **A2**) into Top Panel (Part **1**). Tighten using a Phillips Screwdriver.
- Attach (4) 2MM L Brackets (Part **F**) to Trim Panels (Part **8**) using (4) M3.5 x 16MM Screws (Part **G**). Tighten using Phillips Screwdriver.
- Insert (8) Wood Dowels (Part **B**) into Trim Panels (Part **8**).

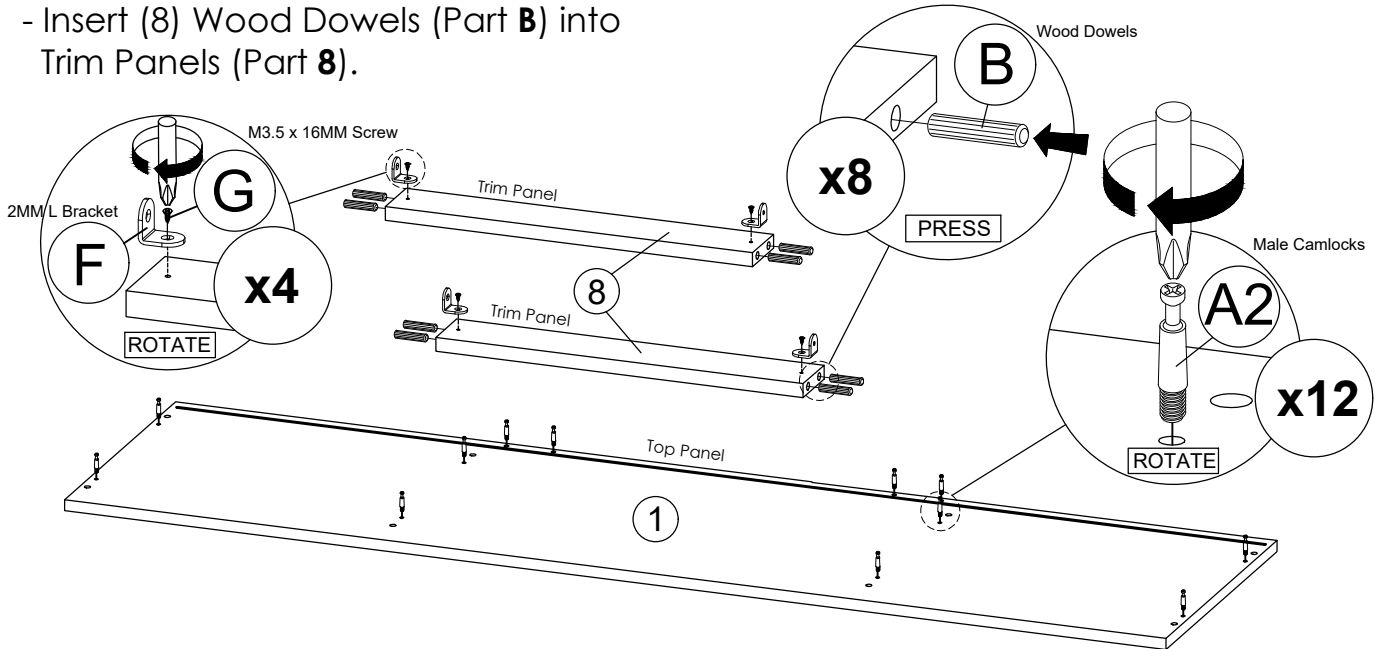

STEP 2

- Insert (12) Female Camlocks (Part **A1**) into panels (3), (4), (5), (6) and (10).
- Insert (16) Wood Dowels (Part **B**) onto panels (3), (4), (5), and (6).

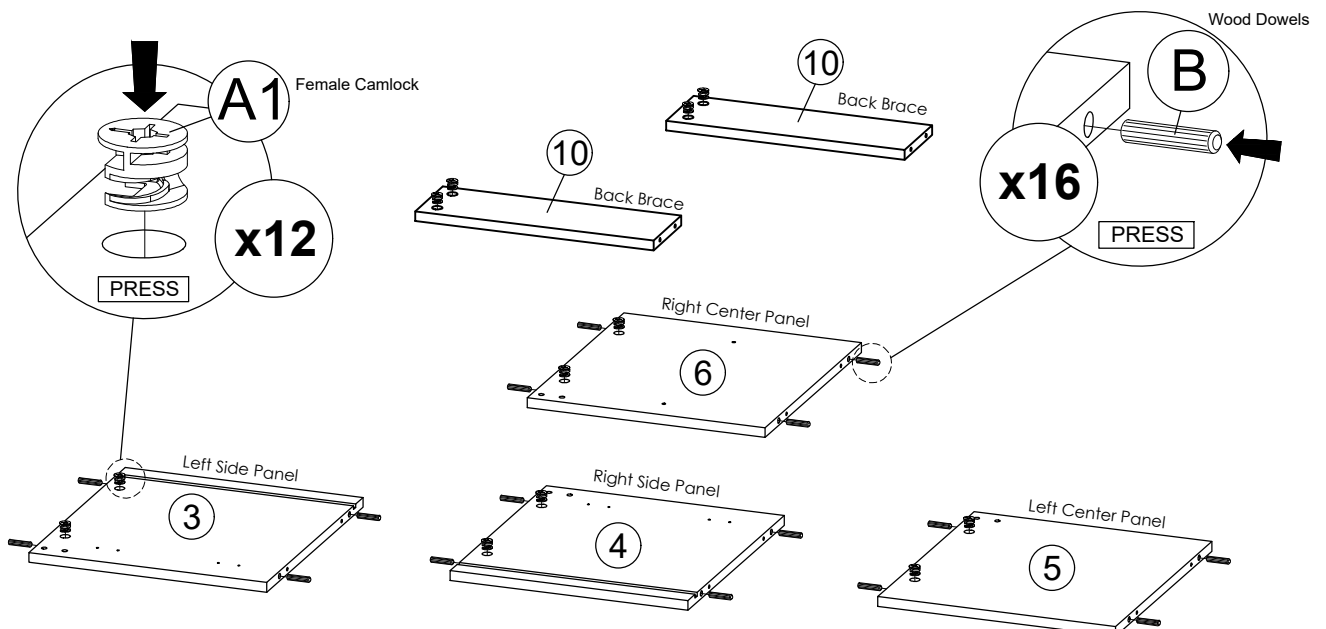

* Ensure the arrows on Female Camlock **A1** point towards outer receiver holes.

STEP 3

- Insert Wood Dowels (Part **B**) on Trim Panel (Part **8**) into receiver holes on Left Side Panel (Part **3**) and Left Center Panel (Part **5**). Repeat these steps for Right Side Panel (Part **4**) and Right Center Panel (Part **6**).

NOTE : Do not attach other end of 2MM L Bracket (Part **F**) in this step. Wood Dowels (Part **B**) will hold panels in place.

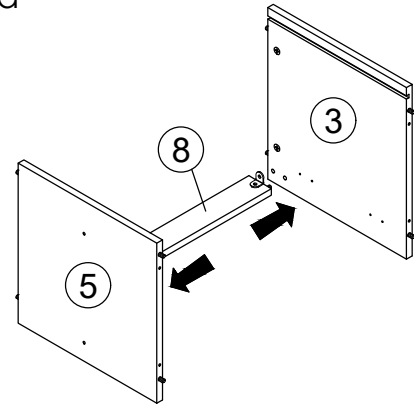
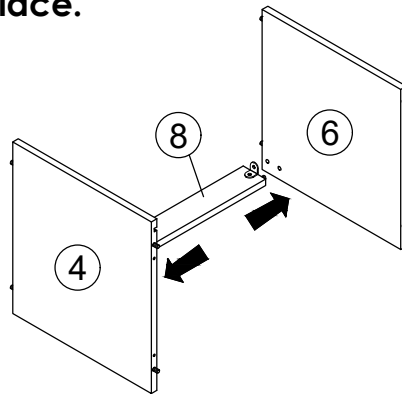

* In this step Wood Dowels **B** are pre-inserted.

STEP 4

- Attach panels (**3**), (**4**), (**5**), (**6**) and (**10**) to underside of Top Panel (Part **1**) by inserting Male Camlocks (Part **A2**) into Female Camlocks (Part **A1**). Tighten with a Phillips Screwdriver.
- Attach (12) Cover Caps (Part **A3**)

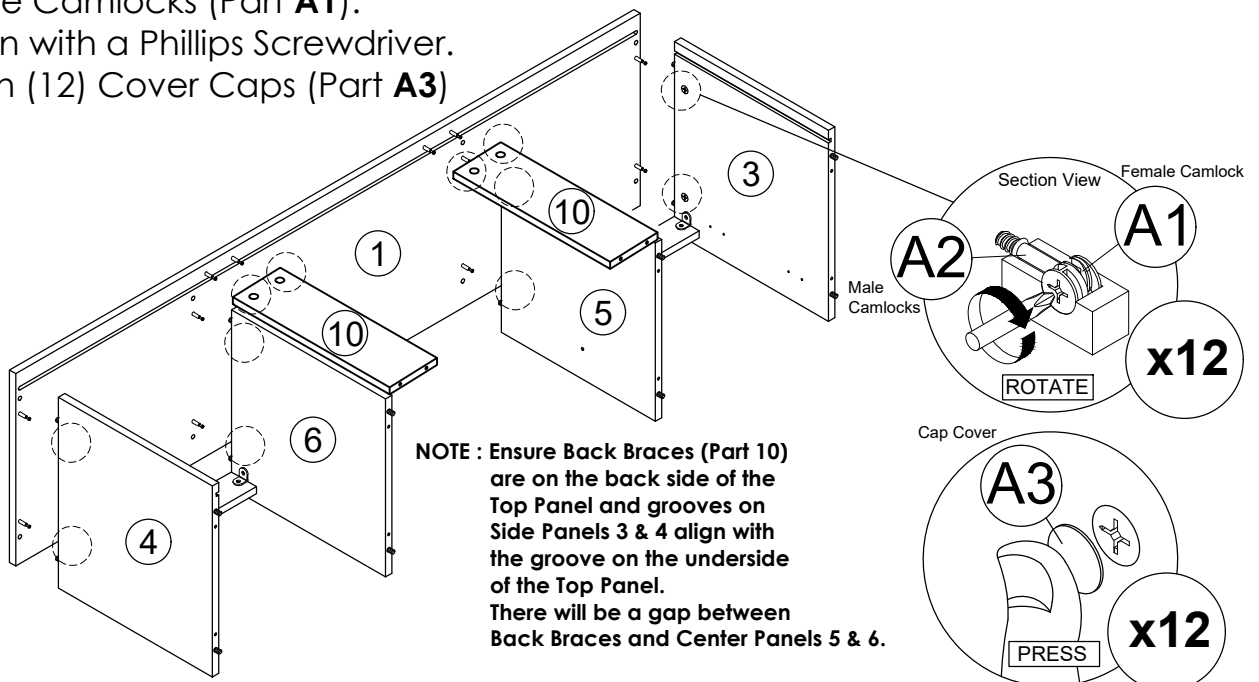

* In this step Female Camlock **A1**, Male Camlock **A2** and Wood Dowels **B** are pre-inserted.

STEP 5

- Attach the 2MM L Brackets (Part **F**) on both Trim Panels (Part **8**) to Side Panels (**3**), (**4**), (**5**), and (**6**) using (4) M3.5 x 16MM Screws (Part **G**).

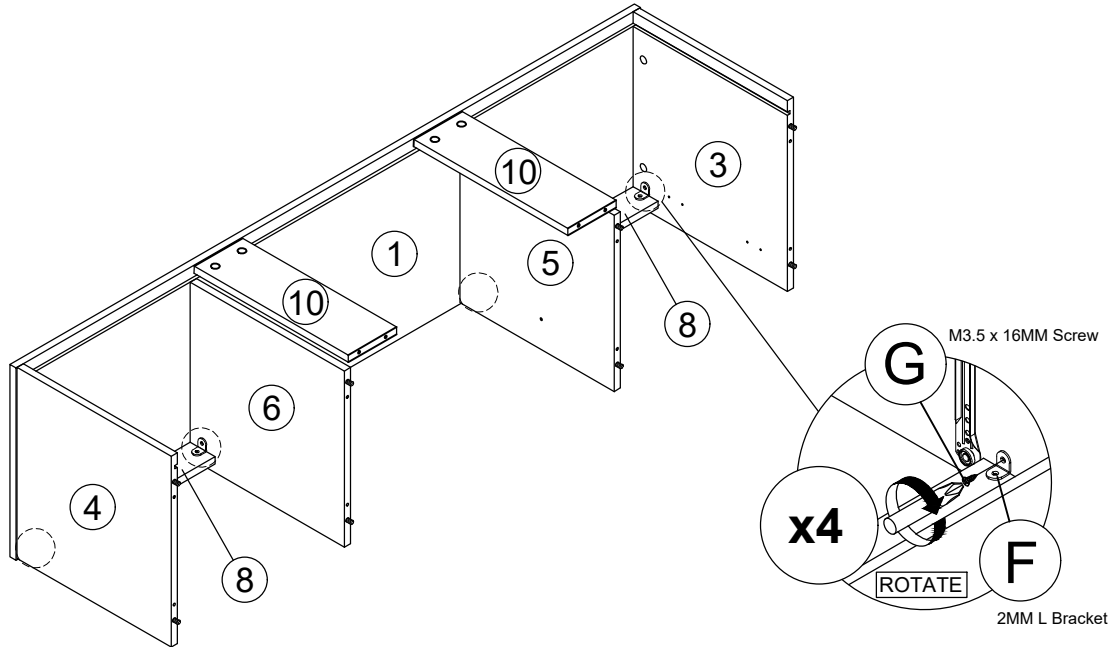

STEP 6

- Insert the Back Panel (Part **9**) into the grooves of Left Side Panel (Part **3**) and Right Side Panel (Part **4**). Ensure Back Panel is securely seated in groove on underside of Top Panel (Part **1**).

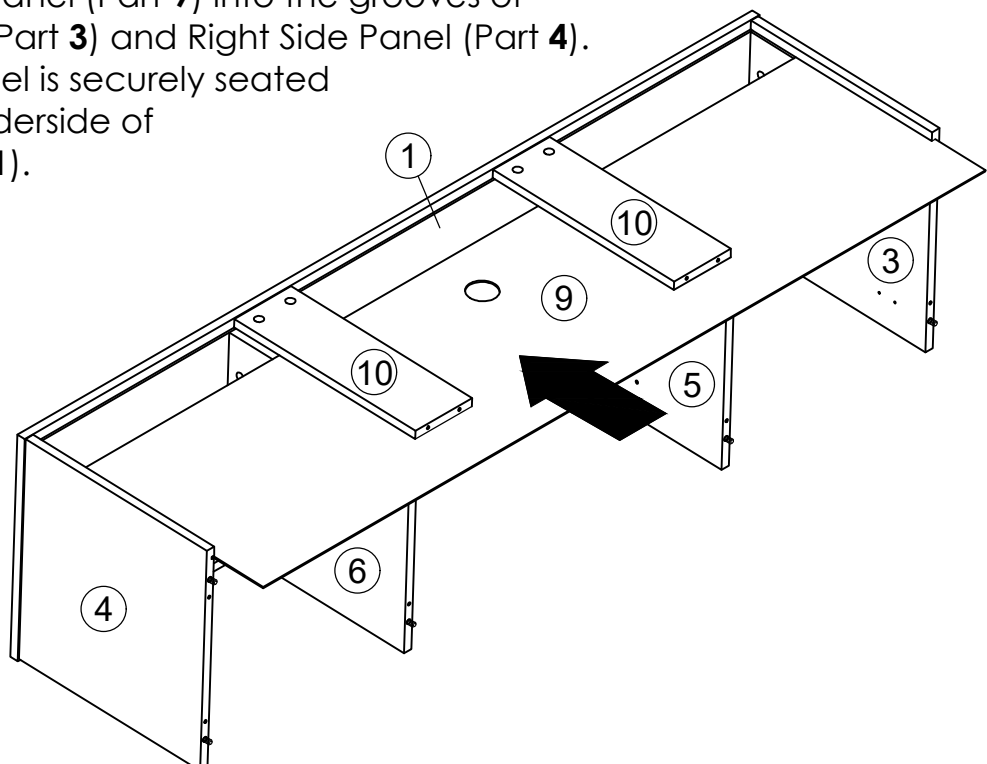

STEP 7

Attach Bottom Panel (Part **2**) to panel (**3**), (**4**), (**5**), (**6**) and (**10**) using (12) M6 x 50MM Hex Wood Screws (Part **C**). Tighten using Allen Wrench M4 (Part **E**).

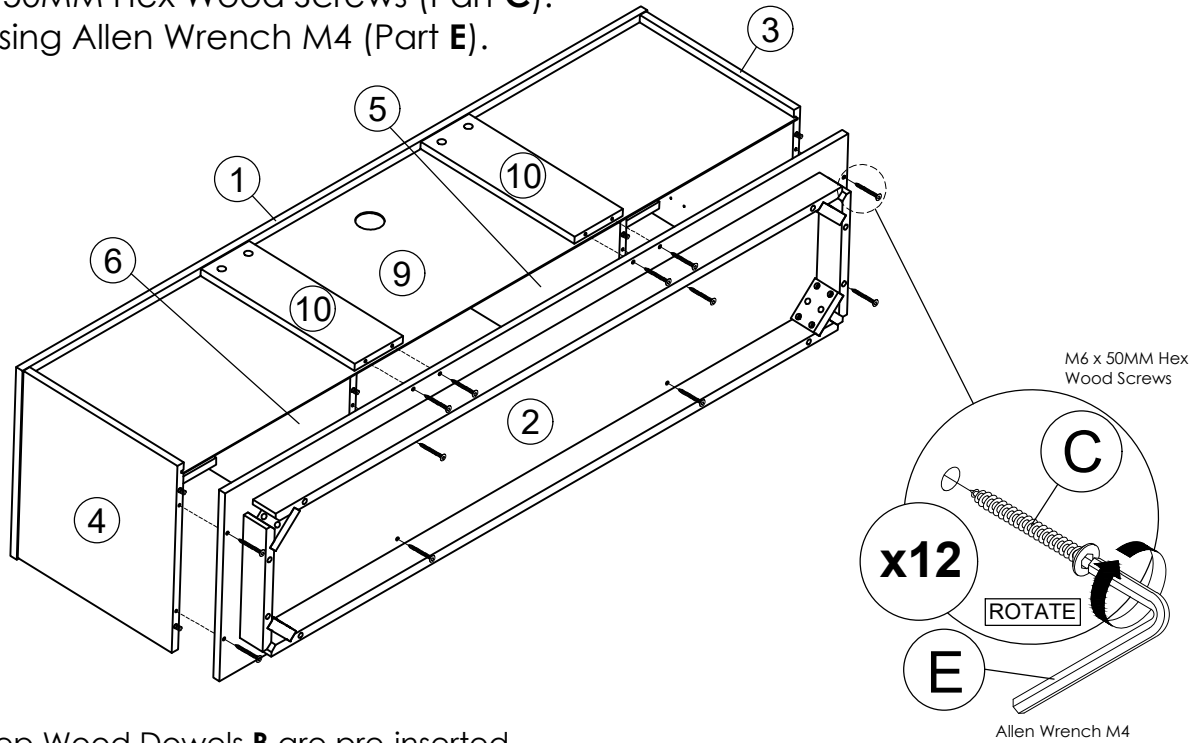

* In this step Wood Dowels **B** are pre-inserted.

STEP 8

- Attach (4) Legs (Part **13**) to Bottom Panel (Part **2**) using (8) Flat Washers M6 (Part **L**), (8) Lock Washers M6 (Part **K**) and (8) Hex Screws M6 x 70 (Part **J**). Tighten using Allen Wrench M4 (Part **E**).
- Using a hammer, gently tap (4) 5/8 PVC Nail-In Floor Glides (Part **D**) into the bottom of the Legs.

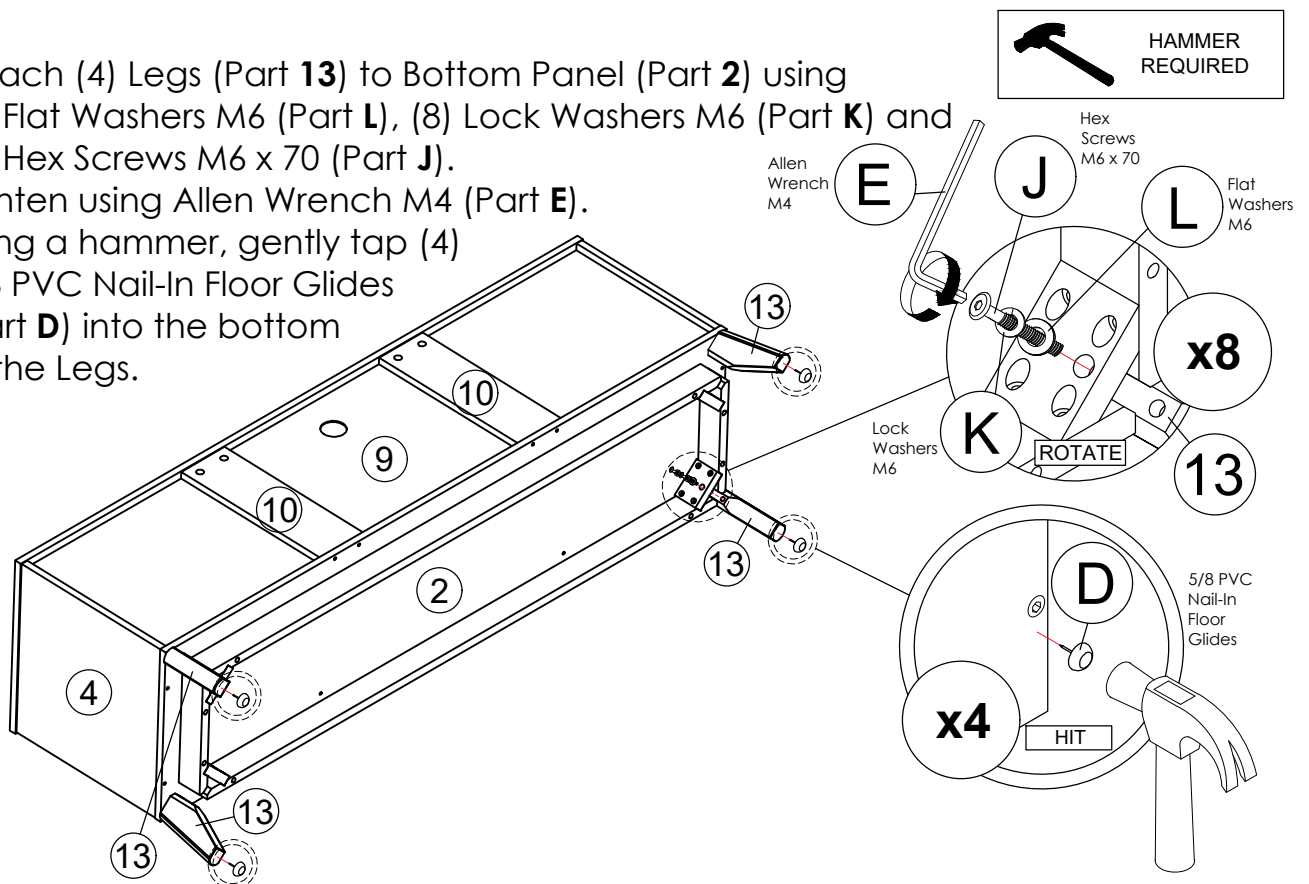

STEP 9

Insert (4) Metal Shelf Supports (Part **1**) into mounting positions on inside of Left Center Panel (Part **5**) and Right Center Panel (Part **6**) by hand.

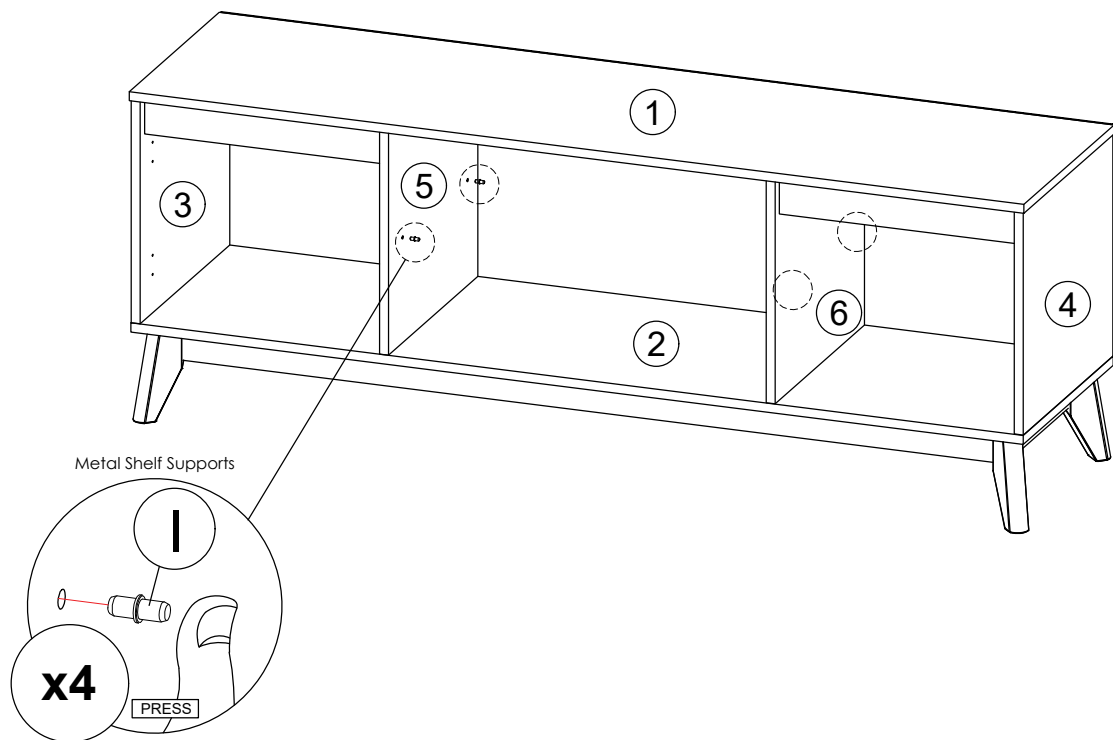

STEP 10

Insert Center Shelf Panel (Part **7**) between Left Center Panel (Part **5**) and Right Center Panel (Part **6**).

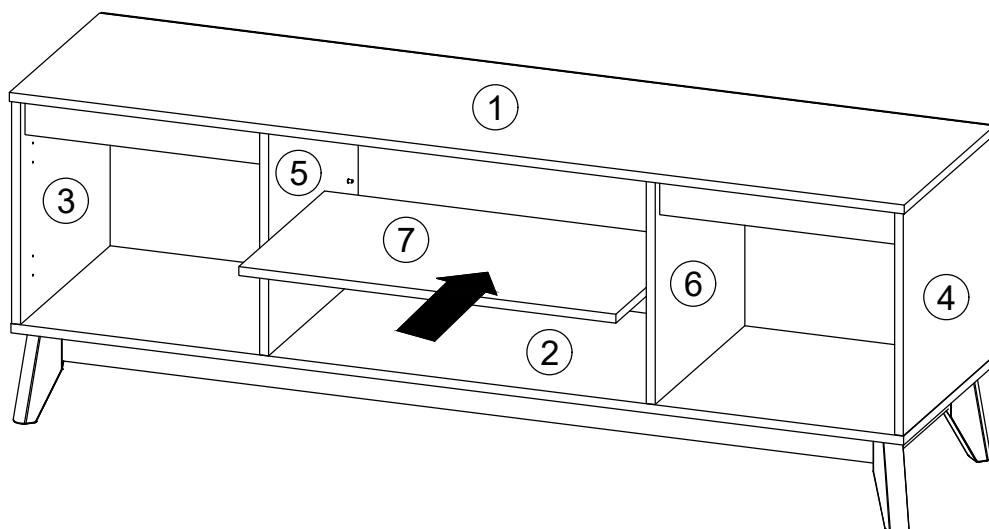

* In this step Metal Shelf Supports **1** are pre-inserted.

STEP 11



Attach (4) Soft Closing 7/8 Hinges (Part **H**) to Left Door Panel (Part **11**) and Right Door Panel (Part **12**) using (8) M3.5 x 16MM Screws (Part **G**). Tighten with a Phillips Screwdriver.

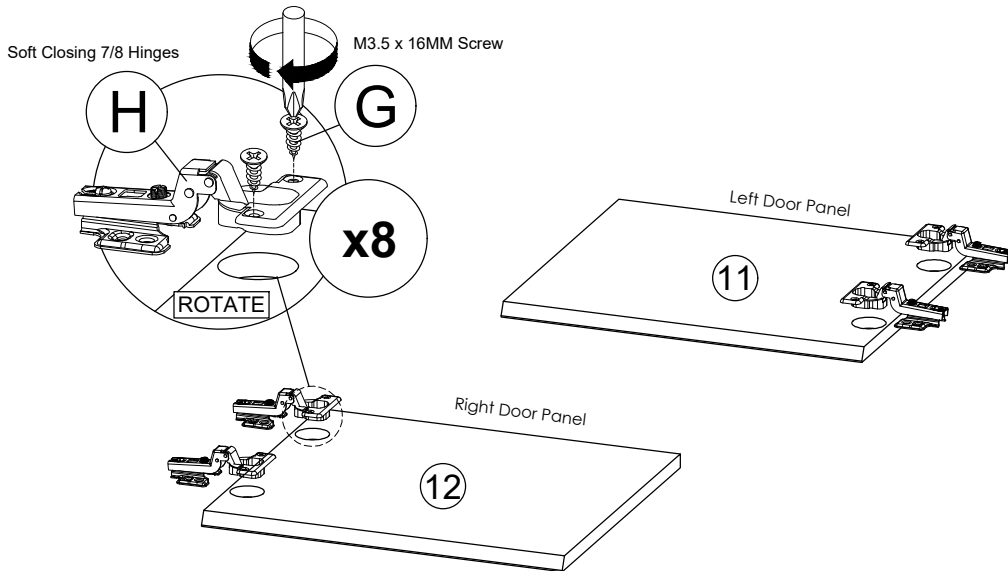

STEP 12



- Attach Soft Closing 7/8 Hinges (Part **H**) to Left Side Panel (Part **3**) and Right Side Panel (Part **4**) using (16) M3.5 x 16MM Screws (Part **G**).
- Tighten or loosen the screw to adjust position of Left Door Panel (Part **11**) and Right Door Panel (Part **12**) for a proper fit.

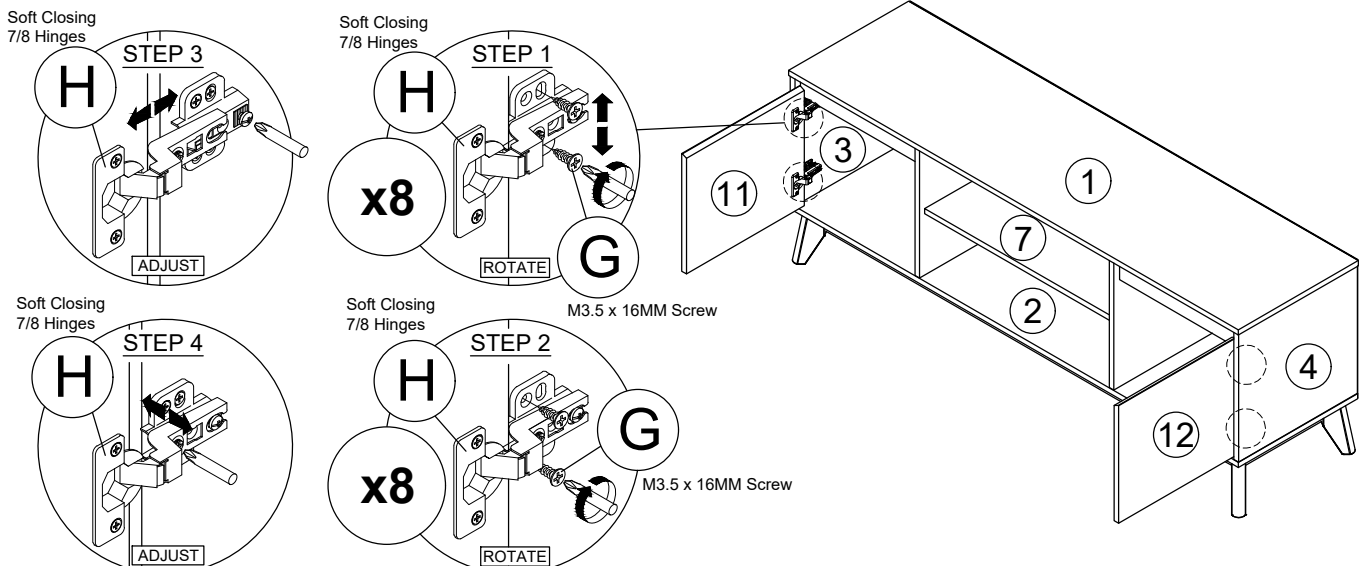

* In this step Soft Closing 7/8 Hinges **H** have been assembled in Door Panels (**11**) and (**12**).