







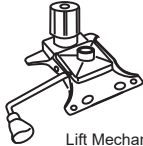

# PARTS

<p><b>(1)x5</b></p>  <p>Casters</p>	<p><b>(2)x1</b></p>  <p>Base</p>	<p><b>(3)x1</b></p>  <p>Gas Lift Cylinder</p>	<p><b>(4)x1</b></p>  <p>Lift Mechanism</p>
<p><b>(5)x1</b></p>  <p>Seat</p>	<p><b>(6)x1</b></p>  <p>Chair Back</p>	<p><b>(7)x1 (L&amp;R)</b></p>  <p>Left Arm      Right Arm</p>	<p><b>(8)x4</b></p>  <p>M8 x 20 Bolt</p>
<p><b>(9)x4</b></p>  <p>M6 x 20 Bolt</p>	<p><b>(10)x4</b></p>  <p>M8 x 50 Bolt</p>	<p><b>(11)x4</b></p>  <p>Arm Cap</p>	<p><b>(12)x1</b></p>  <p>Allen Wrench</p>

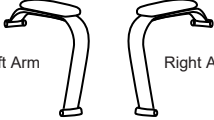
## STEP 1

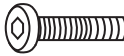
**STEP 1A:** Insert Gas Lift Cylinder (Part 3) into the Base (Part 2).

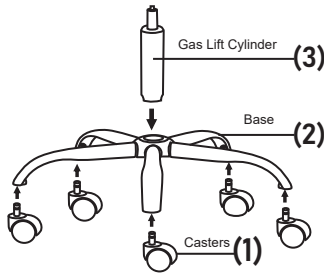

**Step 1B:** Attach Gas Lift Cylinder (Part 3) and casters (Part 1) into the Base (Part 2)

## STEP 2

**STEP 2:** Attach Lift Mechanism (Part 4) to the underside of the Seat (Part 5) using 4 M8 x 20 Bolt (Part 8).

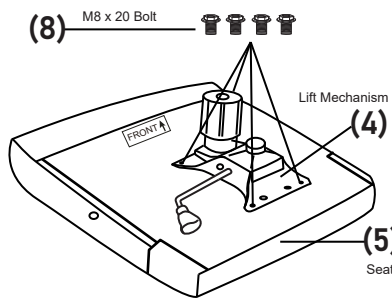

## STEP 3

**STEP 3:** Place seat (Part 5) onto the Gas Lift Cylinder (Part 3).

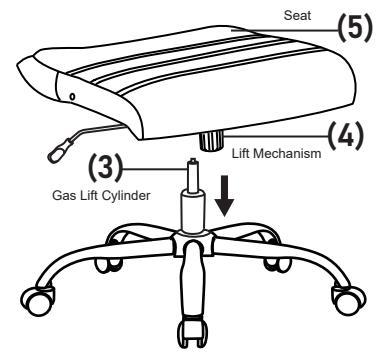

## STEP 4

**STEP 4:** Open the Velcro on both sides of seat first, then place the Back Cushion (Part 6) on the Seat Cushion (Part 5), and use 2 M6 x 20 Bolt (Part 9) to attach to the lower bolt holes on Seat Cushion (Part 5) (see diagram).

\*Note: DO NOT FULLY TIGHTEN BOLTS.

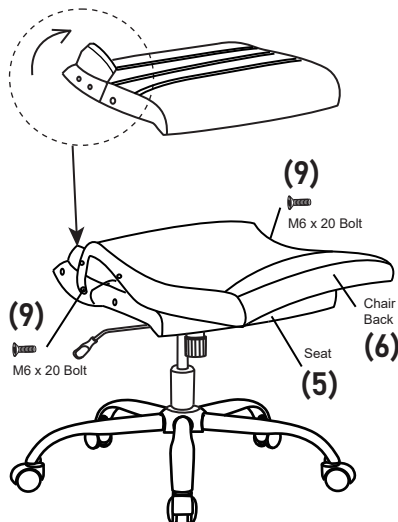

## STEP 5

**STEP 5:** Push the Back Cushion (Part 6) up to a vertical position and attached the Seat Cushion (Part 5) to by using 2 M6 x 20 Bolt (Part 9), then to cover the Velcro back.

\*Note: TIGHTEN THE BOLTS COMPLETELY.

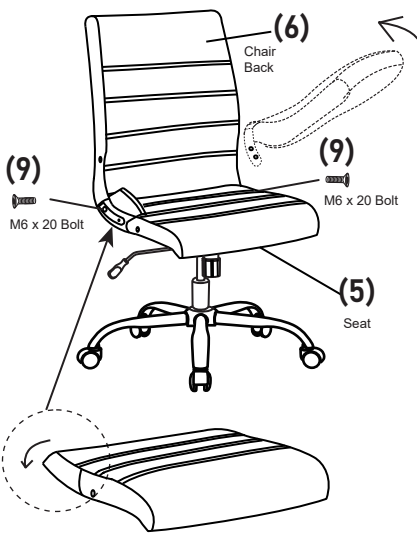

## STEP 6

**STEP 6A:** Attach Left and Right Arms (Part 7) to assembled seat (Part 5 & 6) using 4 M8 x 50 Bolt (Part 10).

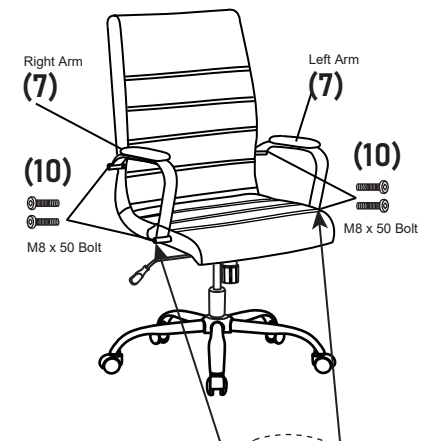

**STEP 6B:** Place the Arm Cap (Part 11) into the arm bolt hole at left and right arm.



Thank you for your purchase!