

Assembly | nstruction

STEP 1.

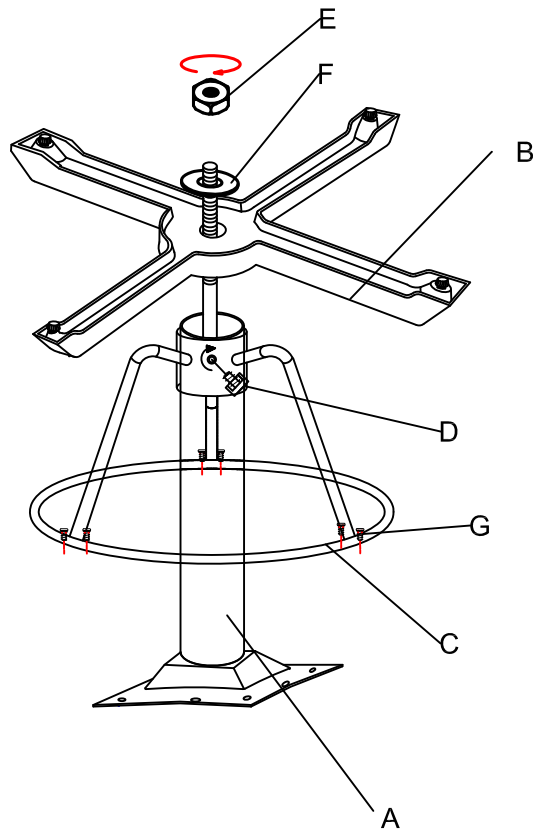

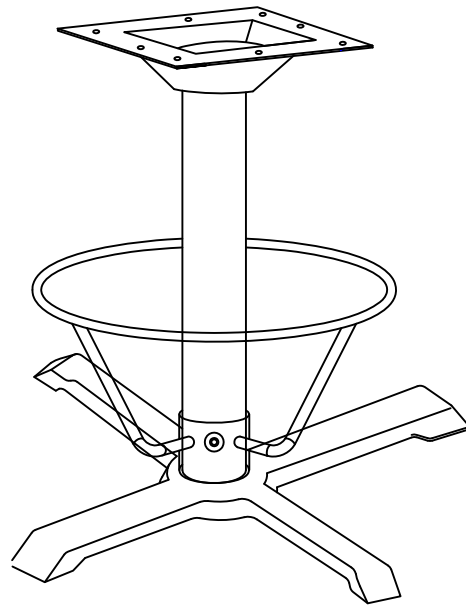



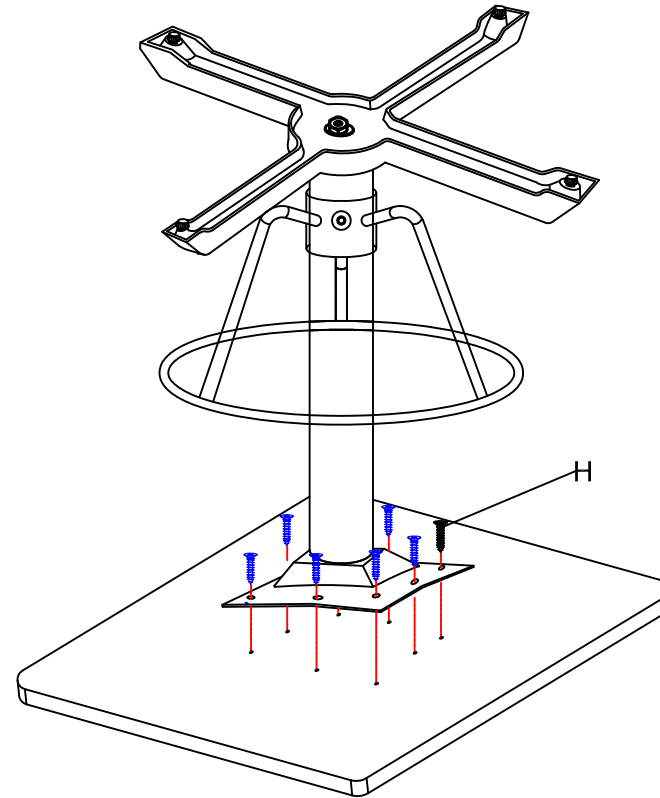

STEP 2.



STEP 3.



PART LIST		QTY
A	TUBE	1pc
B	BASE	1pc
C	PEDAL RING	1pc
D	 BOLT M8*18.5	1pcs
E	 NUT	1pcs
F	 WASHER ϕ 14	1pcs
G	 BOLT 1/4" *15	6pcs
H	 SCREW M5*25	8pcs
I	 ALLEN KEY 4MM	1pc

Tools required:

